

28 MN REACTION SYSTEM COMPONENT OVERVIEW AND SPECIFICATION

AUTHOR M. Plummer	DATE 08/12/2020	 SOCOTEC
DESCRIPTION 28 MN Reaction System Component Overview and Specification		
REFERENCE SCO/28.01	SCALE NTS	PAGE 1

Contents

<u>DESCRIPTION</u>	<u>PAGE</u>
System setup, perspective view	2
System setup, front view	3
System setup, side view	4
System setup, plan view	5
Pile layout	6
Threadbar layout	7
Jacking plate and actuator orientation	8
Primary beam specifications	9
Secondary beam specifications	10
Tension element specifications	11
Load saddle specifications	12
Trestle specifications	13
Hydraulic actuator and load cell details	14

This document describes the components used in the 28 MN reaction system for maintained load testing. All components are used in a modular setup with calculated capacities applied at the stated predetermined spacing. The loading beams and all associated components have been designed specifically for maintained loading.

All materials used in load bearing capacities are assumed to be homogenous and isotropic with a lower bound yield stress of 320 MPa, however all components are composed of steels in excess of this. All welds are of a minimum throat of 6 mm that were inspected with NDT techniques post-fabrication and follow regular visual inspections and before each testing regime.

All load measuring equipment is calibrated to UKAS standards with full traceability. All hydraulic equipment follows a set maintenance schedule whereby it is proof tested to 150% of maximum operating capacity and includes pressure relief valving. The reaction system is restrained by a number of high-grade, prestressing steel threadbar specified by SOCOTEC and installed by the piling contractor.

Schedule of Components

<u>ITEM</u>	<u>QUANTITY</u>	<u>PAGE</u>
12 m primary beam	4 no.	9
8 m secondary beam	4 no.	10
tension element	4 no.	11
load saddle	1 no.	12
trestles	2 no.	13
jacking plate	1 no.	8
hydraulic actuator	2 no.	14
load cell	2 no.	14

28 MN Reaction Frame

Perspective View

AUTHOR M. Plummer	DATE 08/12/2020	
DESCRIPTION 28 MN Reaction System Component Overview and Specification		
REFERENCE SCO/28.01	SCALE NTS	PAGE 2

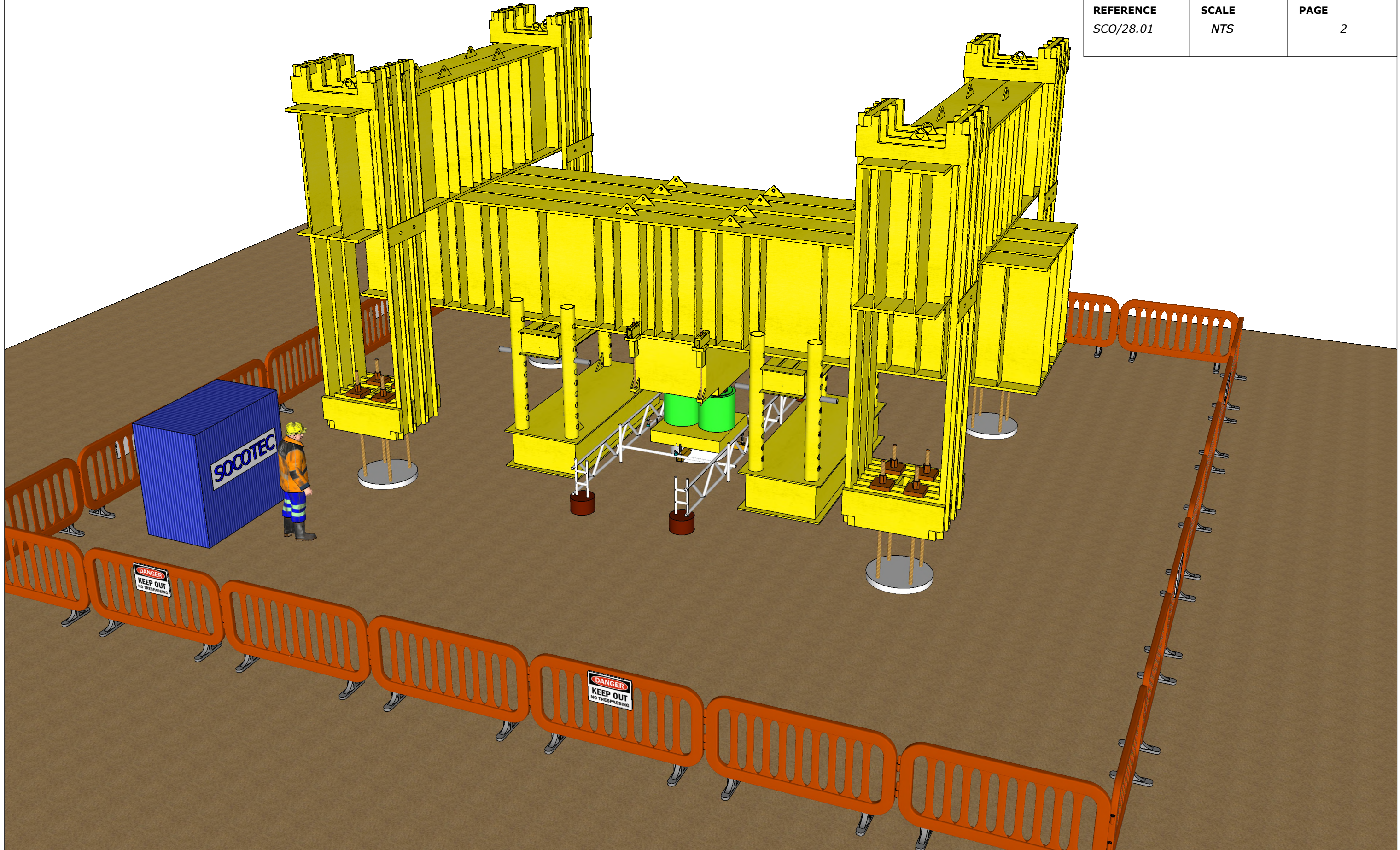

*28 MN Reaction Frame
Front View*

AUTHOR M. Plummer	DATE 08/12/2020	 SOCOTEC
DESCRIPTION 28 MN Reaction System Component Overview and Specification		
REFERENCE SCO/28.01	SCALE 1 : 50	PAGE 3

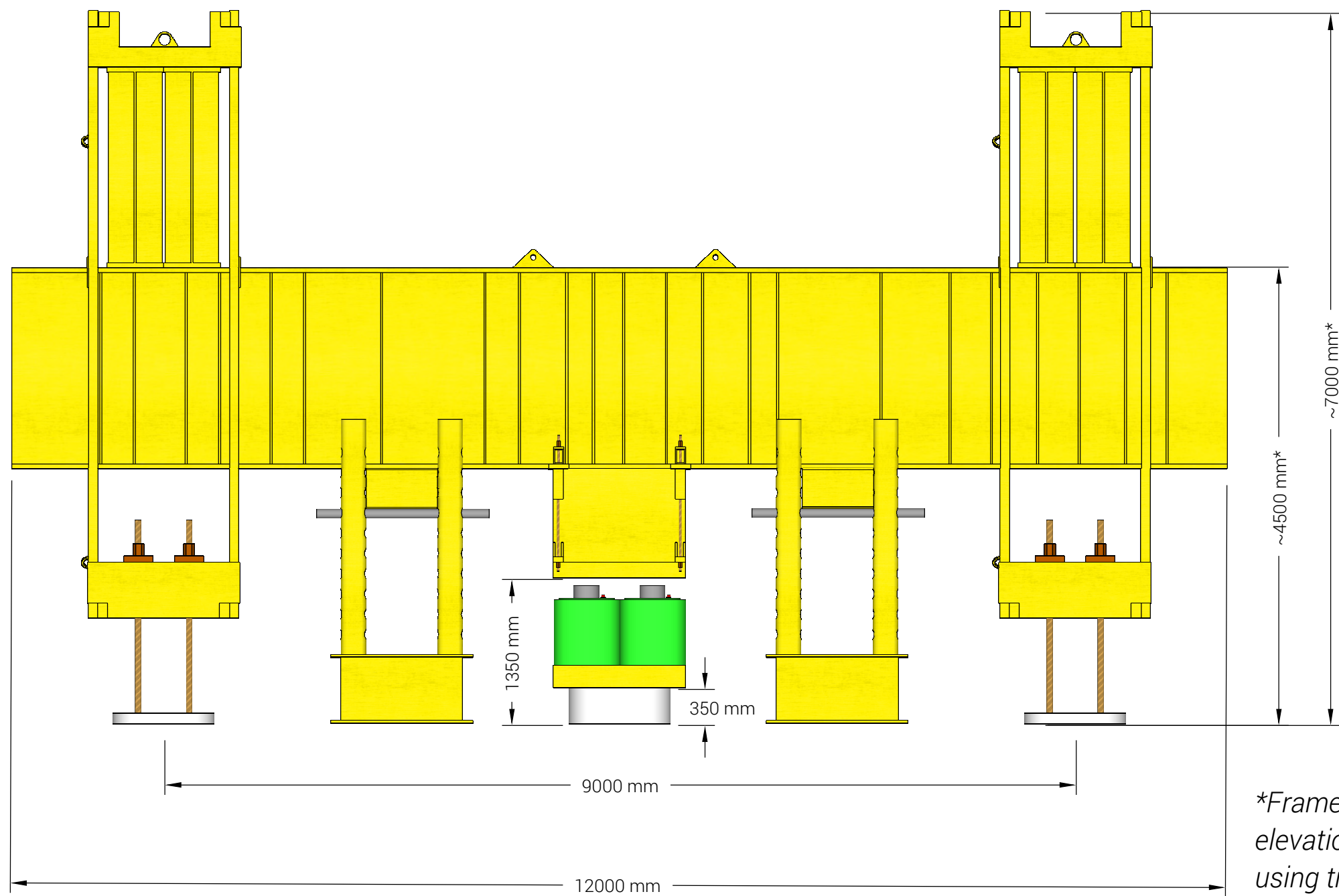

NOTES

**Frame height is dependent on pile cap elevation; frame adjusted to accommodate using trestles*

28 MN Reaction Frame
Side View

AUTHOR M. Plummer	DATE 08/12/2020	 SOCOTEC
DESCRIPTION 28 MN Reaction System Component Overview and Specification		
REFERENCE SCO/28.01	SCALE 1 : 50	PAGE 4

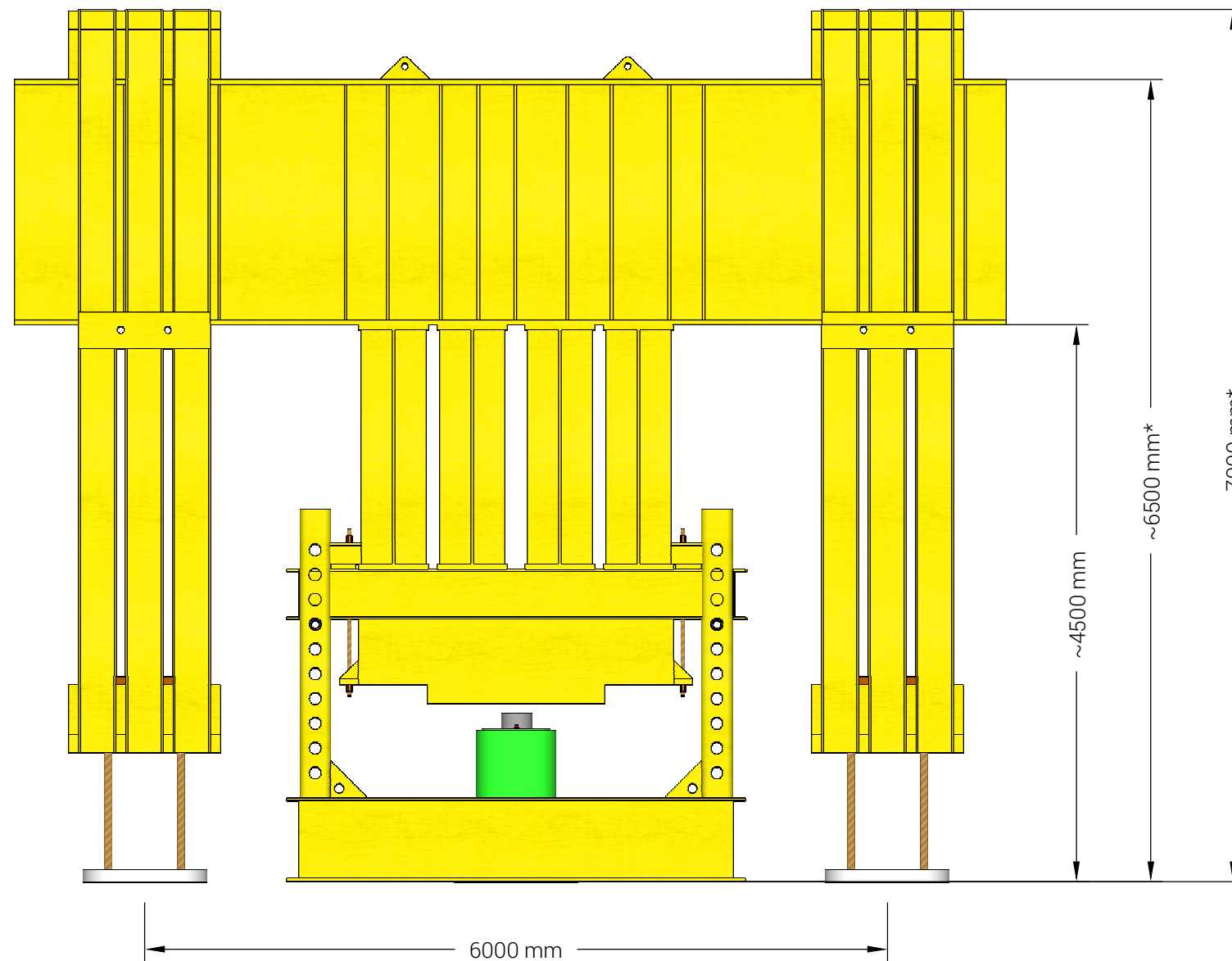

NOTES

**Frame height is dependent on pile cap elevation; frame adjusted to accommodate using trestles*

28 MN Reaction Frame
Top View

AUTHOR M. Plummer	DATE 08/12/2020	 SOCOTEC
DESCRIPTION 28 MN Reaction System Component Overview and Specification		
REFERENCE SCO/28.01	SCALE 1 : 50	PAGE 5

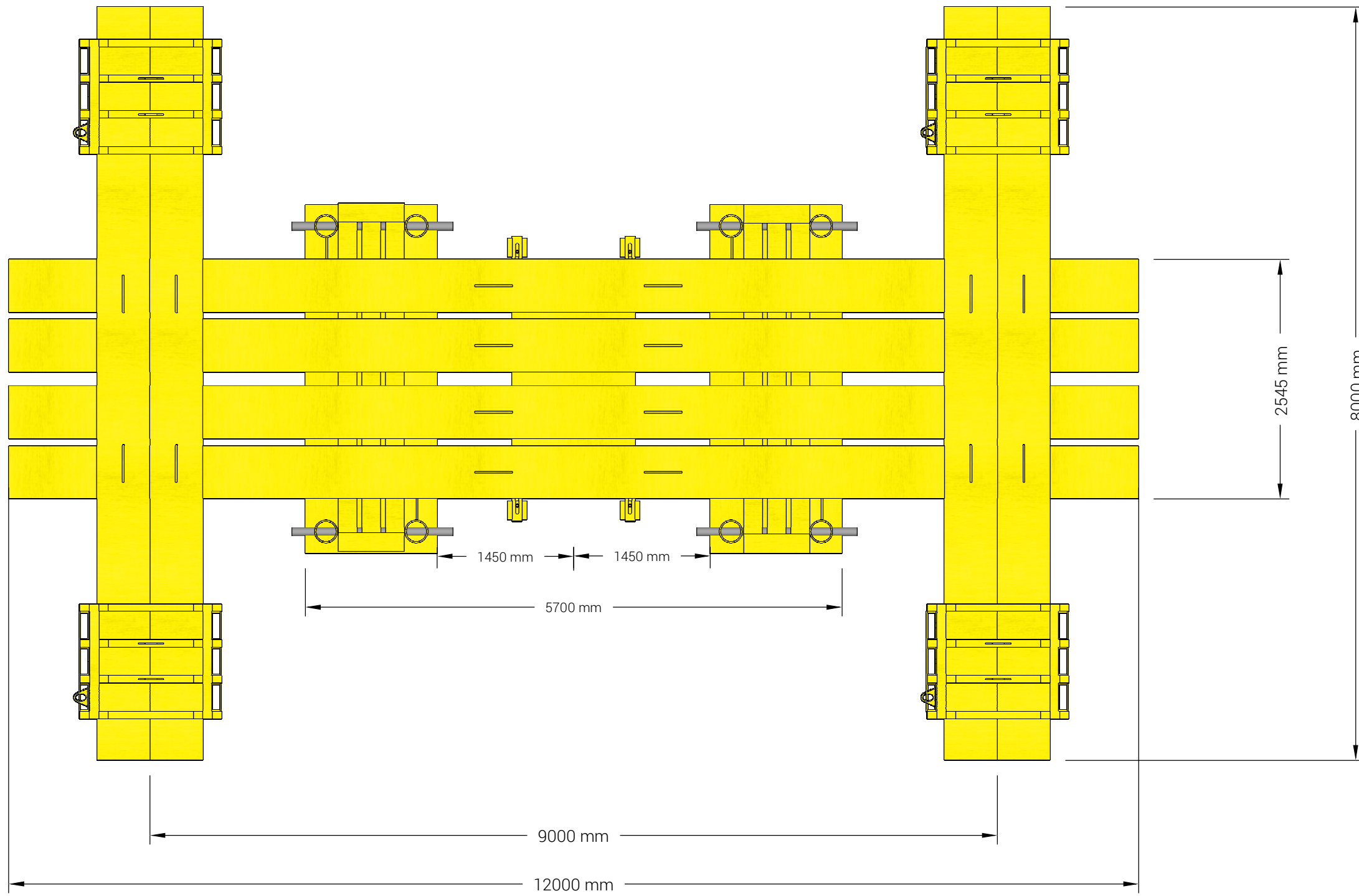

PILE LAYOUT

AUTHOR M. Plummer	DATE 08/12/2020	
DESCRIPTION 28 MN Reaction System Component Overview and Specification		
REFERENCE SCO/28.01	SCALE 1:40	PAGE 6

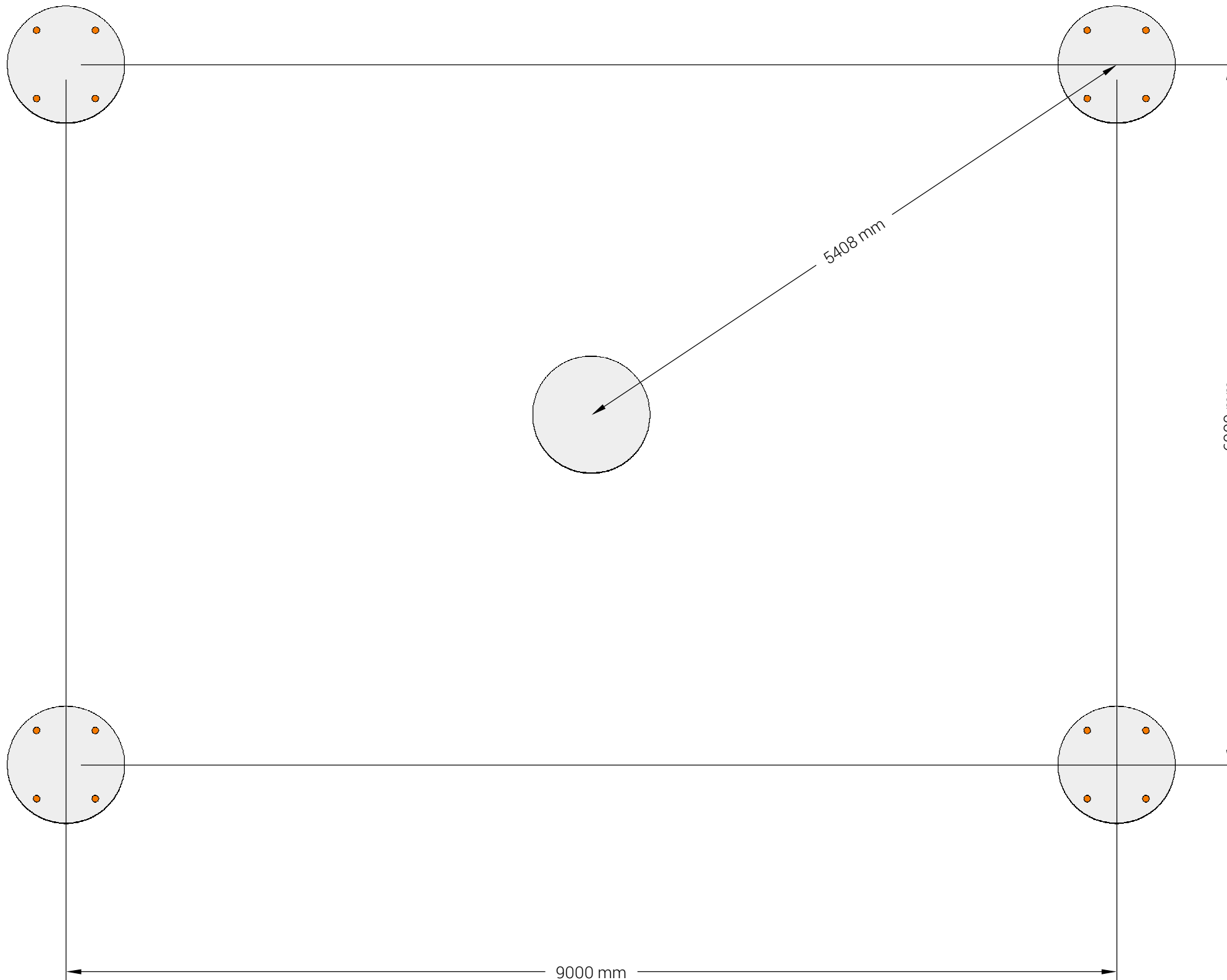

NOTES

All dimensions shown are to centre of pile.

Standard dimensions shown; other variations are possible.

Allowable tolerance of pile positions is 25 mm.

All pile design aspects including threadbar capacity, steel reinforcement and load bearing capacity is the responsibility of the client. Anchor spacing should fulfil ICE Specification of a minimum of 3x pile diameter.

The test pile cap should be finished with a level, smooth surface adequate to accommodate the imposed loading and 300 mm above ground level.

The platform should be flat and level and suitable to support the mass of the reaction frame.

THREADBAR LAYOUT

AUTHOR
M. Plummer

DATE
08/12/2020



DESCRIPTION

28 MN Reaction System Component Overview and Specification

REFERENCE

SCO/28.01

SCALE

1:20

PAGE

7

Anchors 1 - 4

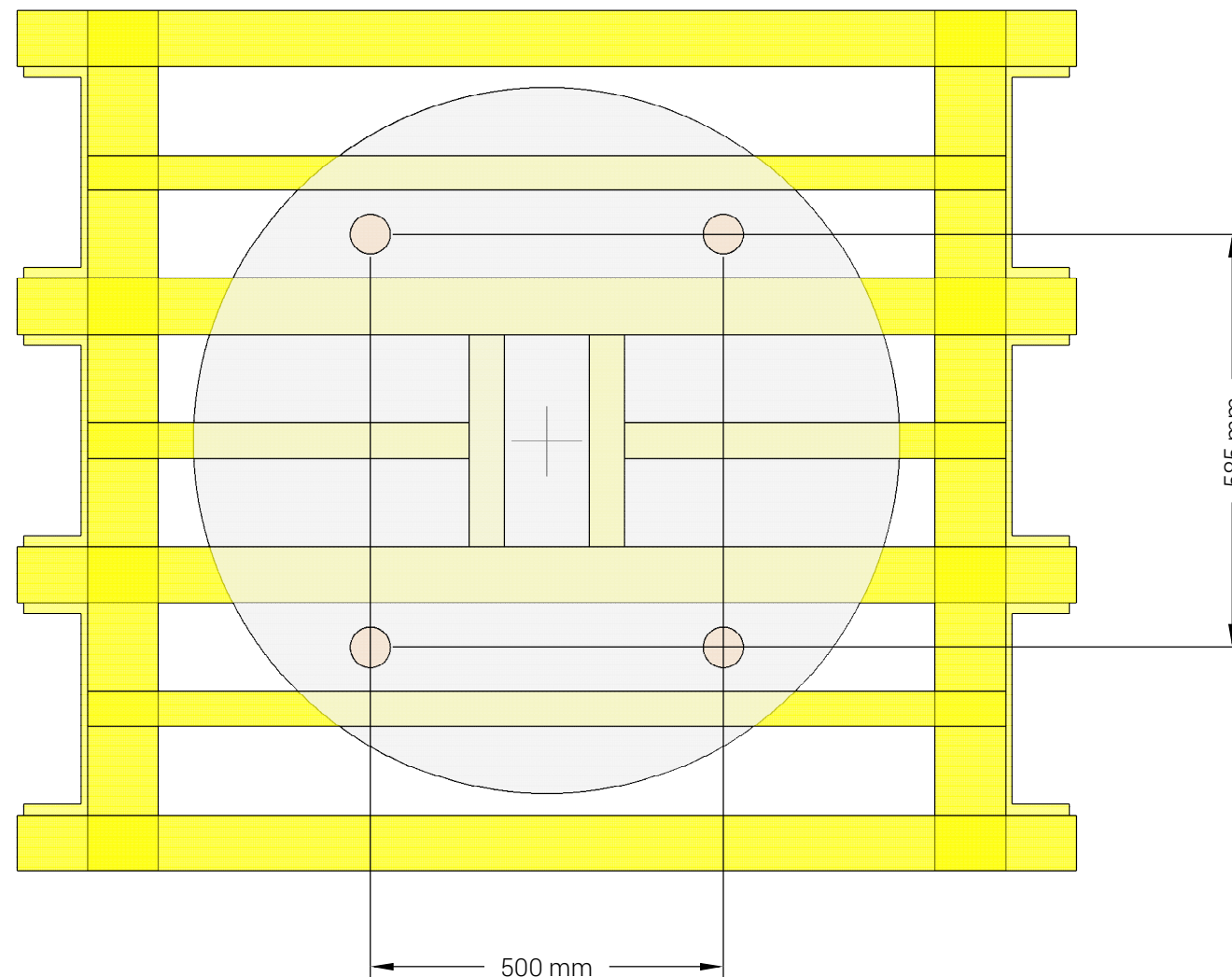

NOTES

The sketch shows a suggested number and orientation of bars. Other variations are possible to accommodate different pile diameters and cage designs on request.

All bars should be DSI 950/1050 grade Prestressing threadbar.

All bars should be finished to 2 m above the test cap level (not ground) and be straight, normal to the reaction pile and free from damage and concrete.

Allowable tolerance on bar position is 25 mm.

Diameter of bar should be chosen to facilitate intended imposed bar loading plus 10% to allow for uneven loading through reaction system.

JACKING PLATE AND ACTUATOR ORIENTATION

AUTHOR M. Plummer	DATE 08/12/2020	
DESCRIPTION 28 MN Reaction System Component Overview and Specification		
REFERENCE SCO/28.01	SCALE NTS	PAGE 8

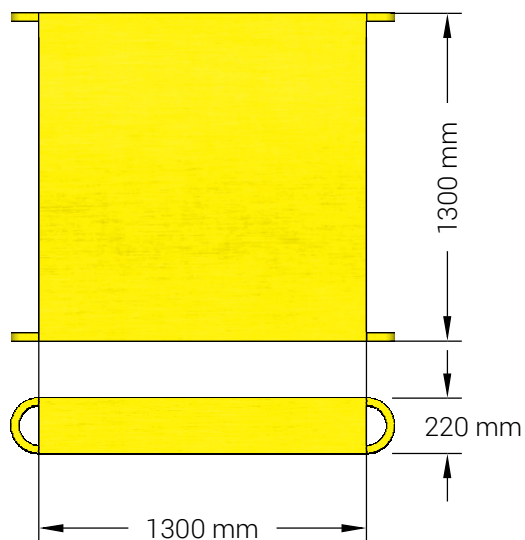
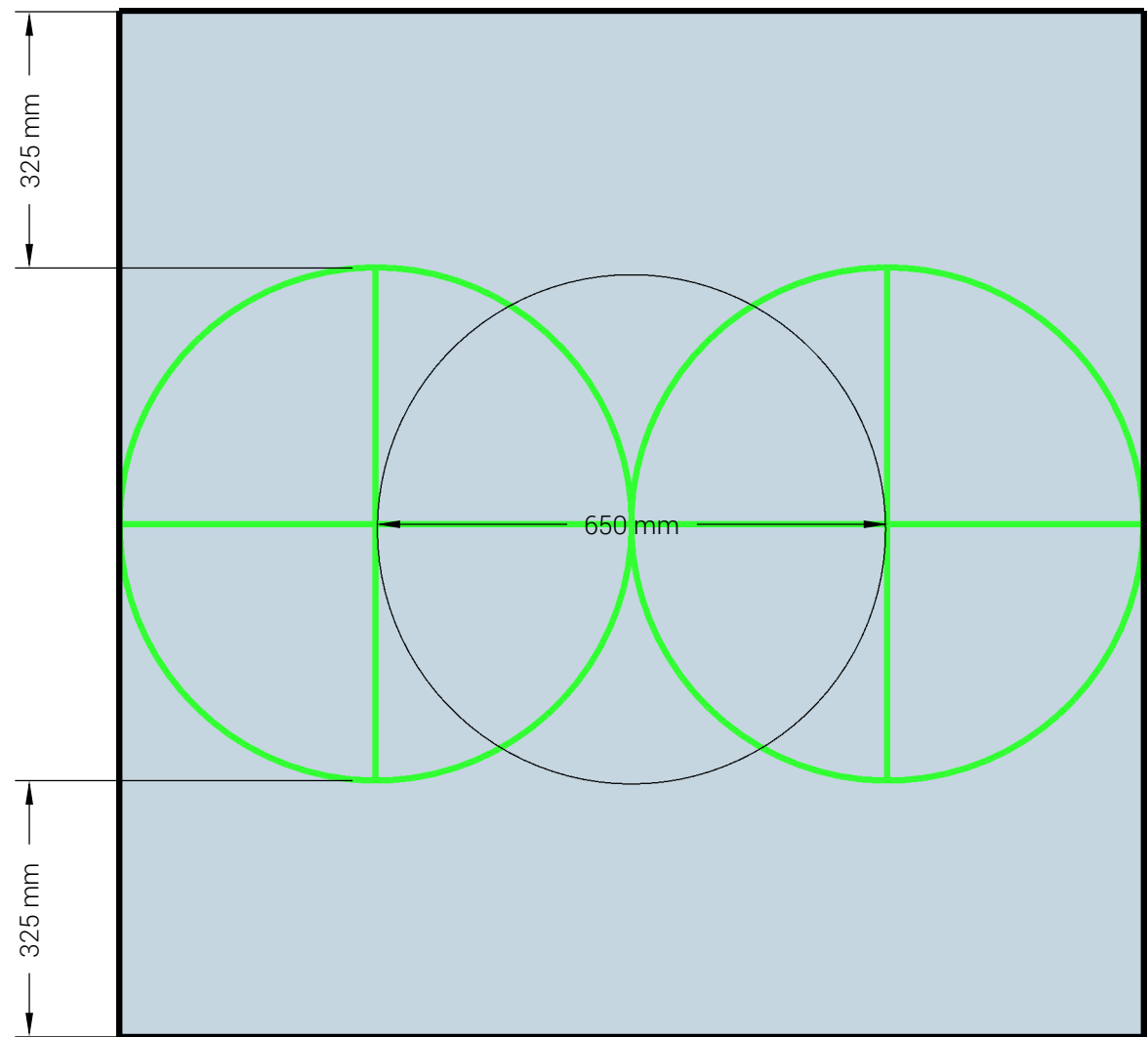

NOTES

The sketch shows accommodation of 2 no. $\phi 650$ mm actuators (in green) on a 1300 mm x 1300 mm jacking plate. Each actuator is located on a line central to the plate, equidistant from the centre and in line with the primary beams. Positions of each actuator are marked on the plate to aid with locating. A measurement is taken underneath the plate to locate the plate on the pile.

Note that the pile is not detailed here

PRIMARY BEAM SPECIFICATIONS

AUTHOR
M. Plummer

DATE
08/12/2020



DESCRIPTION
28 MN Reaction System Component Overview and Specification

REFERENCE
SCO/28.01

SCALE
1 : 50

PAGE
9

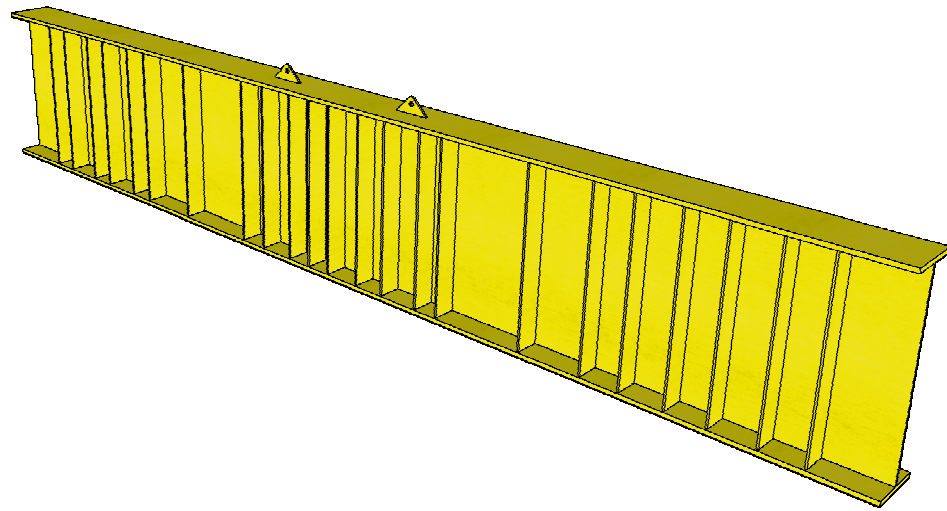

A 12 m high-capacity loading beam used in modular configurations of reaction systems. It is composed of high strength steel and contains lateral stiffeners across its span and integrated lifting eyes.

NOTES

Mass = 13500 kg

Section Details

$A = 9.14 \times 10^4 \text{ mm}^2$
 $I_{xx} = 5.91 \times 10^{10} \text{ mm}^4$
 $S_{xx} = 5.97 \times 10^7 \text{ mm}^3$
 $M_b = 19100 \text{ kNm}$

All stiffeners in pairs of 250 mm x 20 mm fully fitted plate.

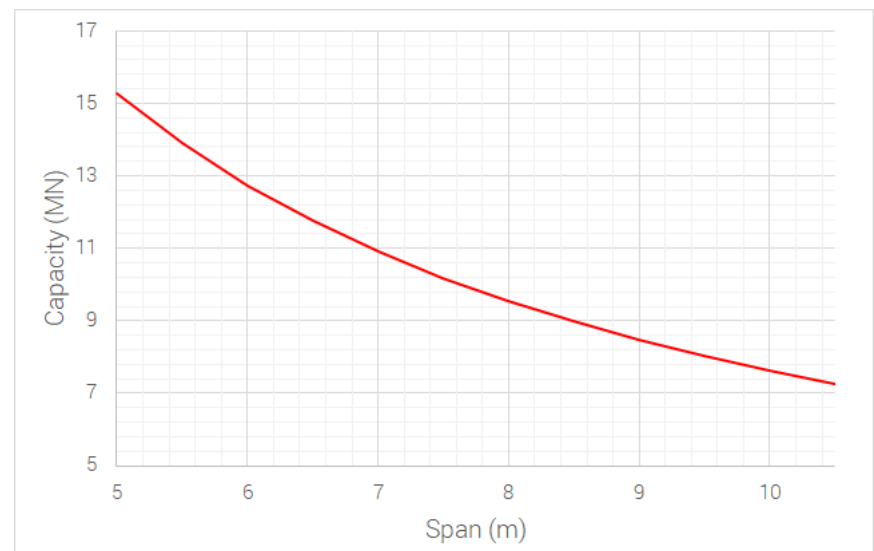
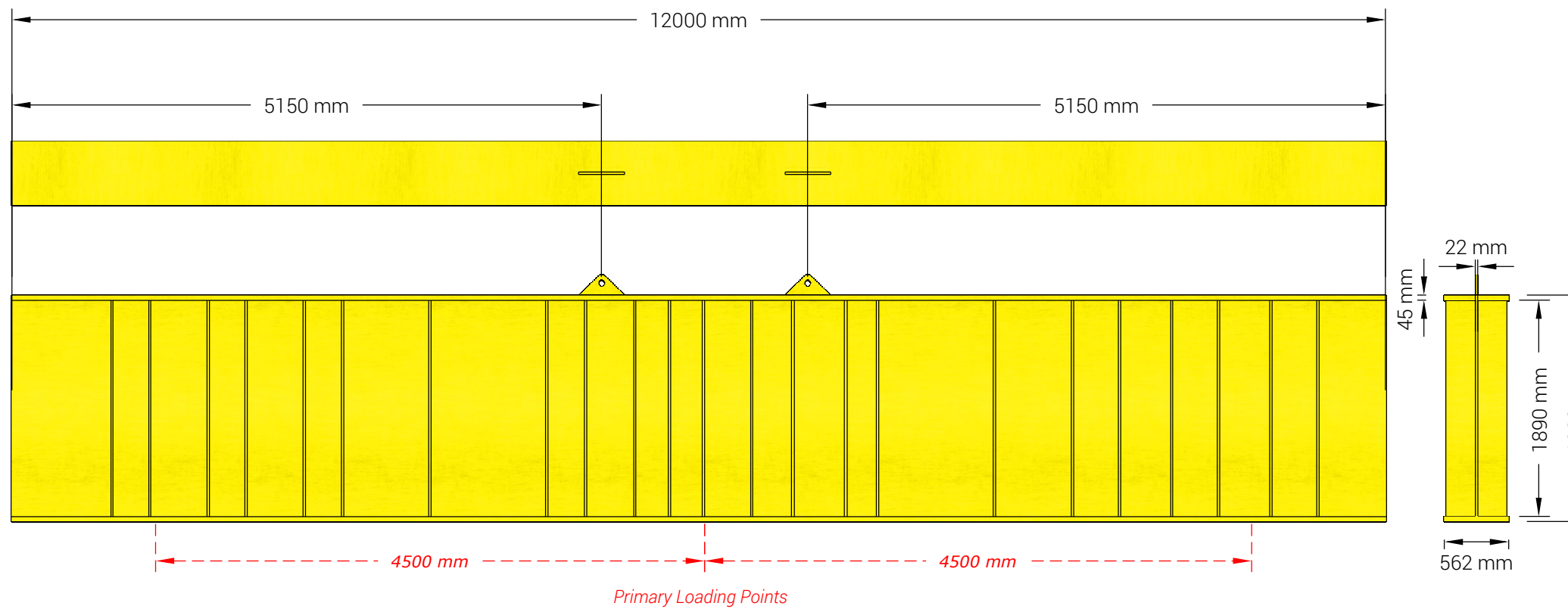

SECONDARY BEAM SPECIFICATIONS

AUTHOR M. Plummer	DATE 08/12/2020	
DESCRIPTION 28 MN Reaction System Component Overview and Specification		
REFERENCE SCO/28.01	SCALE 1 : 50	PAGE 10

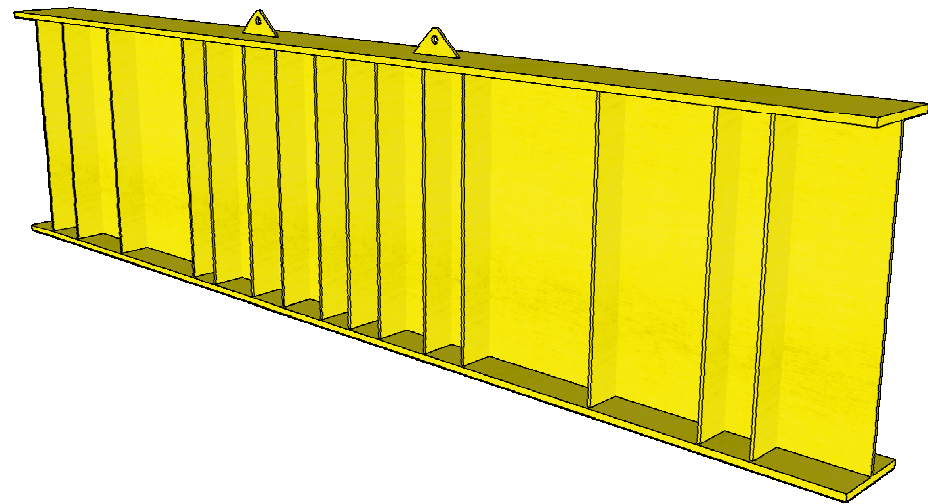

An 8 m high-capacity loading beam used in modular configurations of reaction systems. It is composed of high strength steel and contains lateral stiffeners across its span and integrated lifting eyes.

NOTES

Mass = 8700 kg

Section Details

$A = 9.14 \times 10^4 \text{ mm}^2$
 $I_{xx} = 5.91 \times 10^{10} \text{ mm}^4$
 $S_{xx} = 5.97 \times 10^7 \text{ mm}^3$
 $M_b = 19100 \text{ kNm}$

All stiffeners in pairs of 250 mm x 20 mm fully fitted plate.

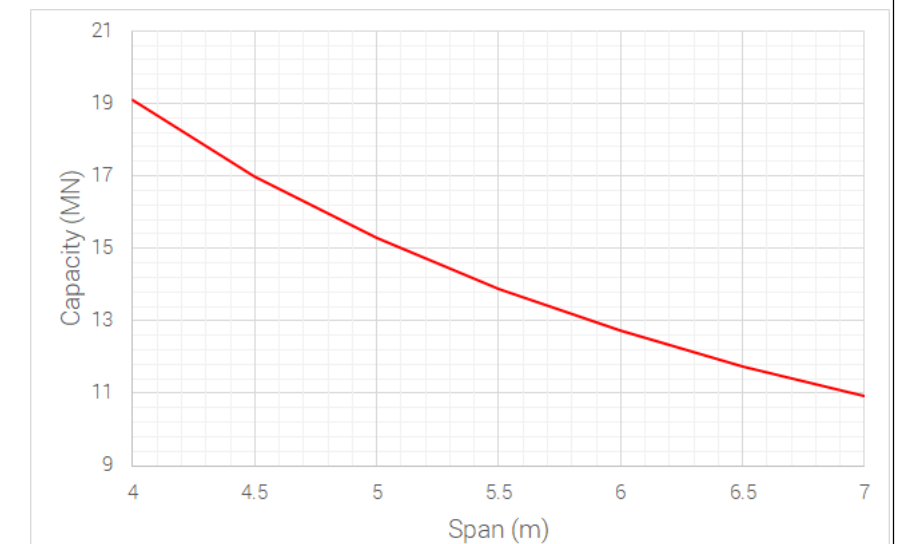
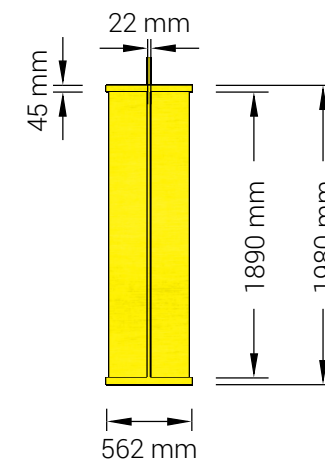
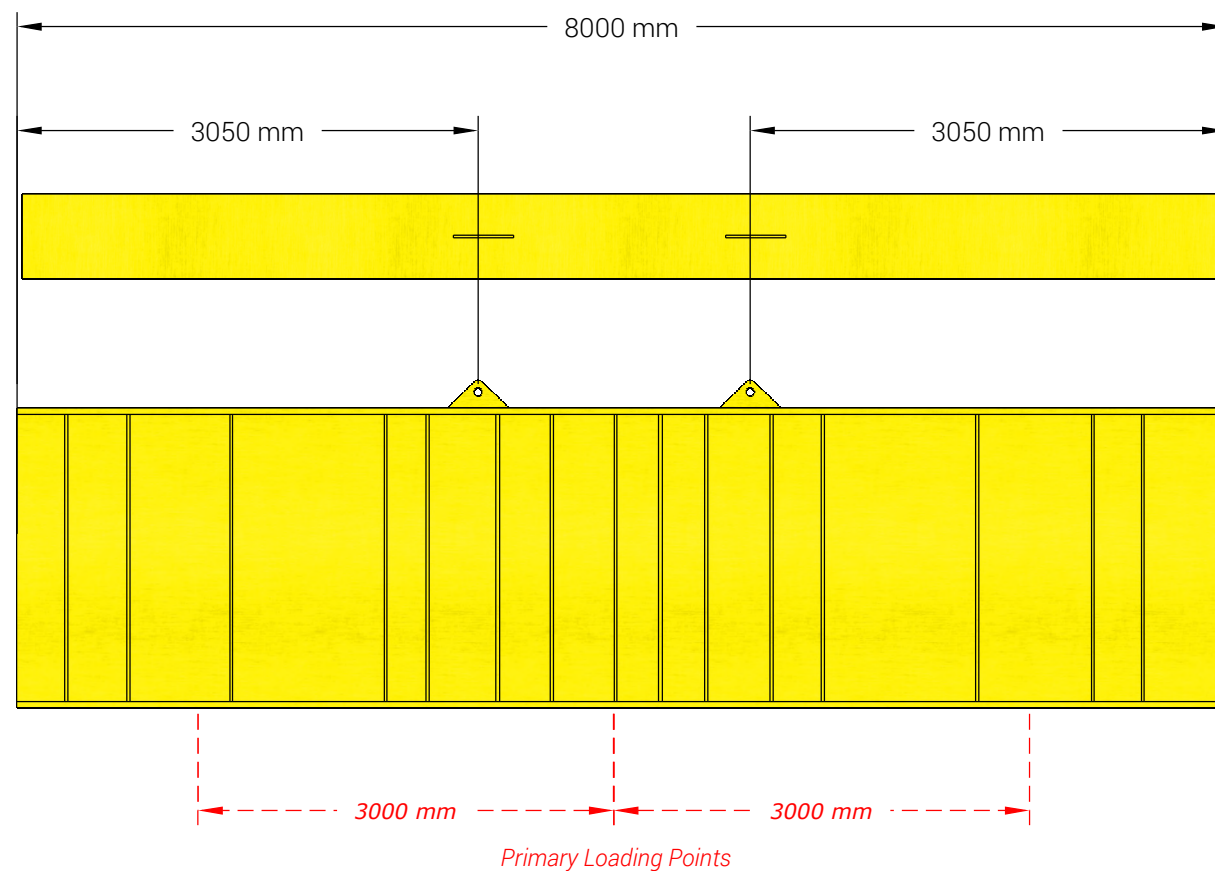

TENSION ELEMENT SPECIFICATIONS

AUTHOR M. Plummer	DATE 08/12/2020		
DESCRIPTION 28 MN Reaction System Component Overview and Specification			
REFERENCE SCO/28.01	SCALE 1 : 30	PAGE 11	

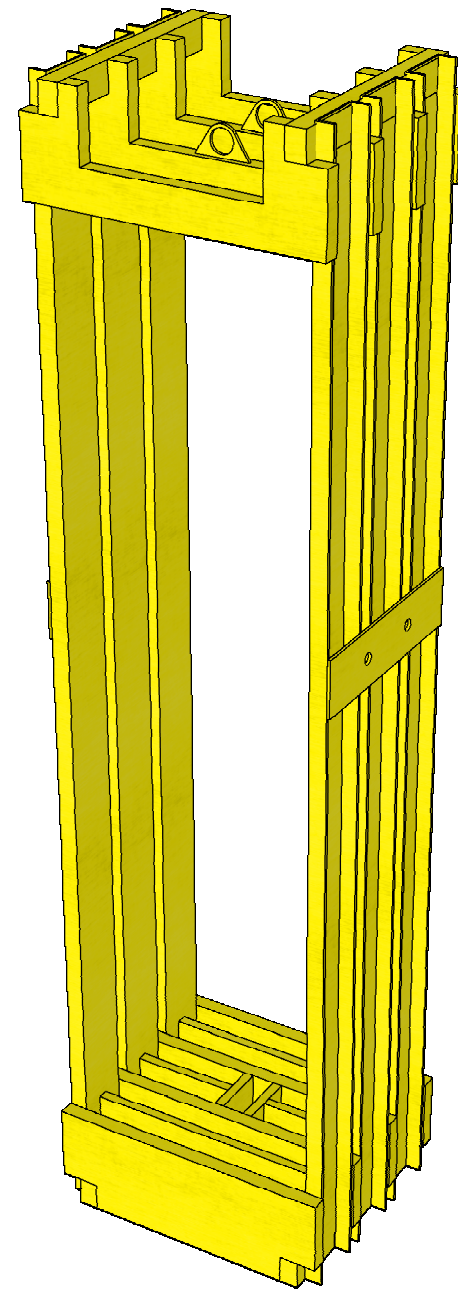
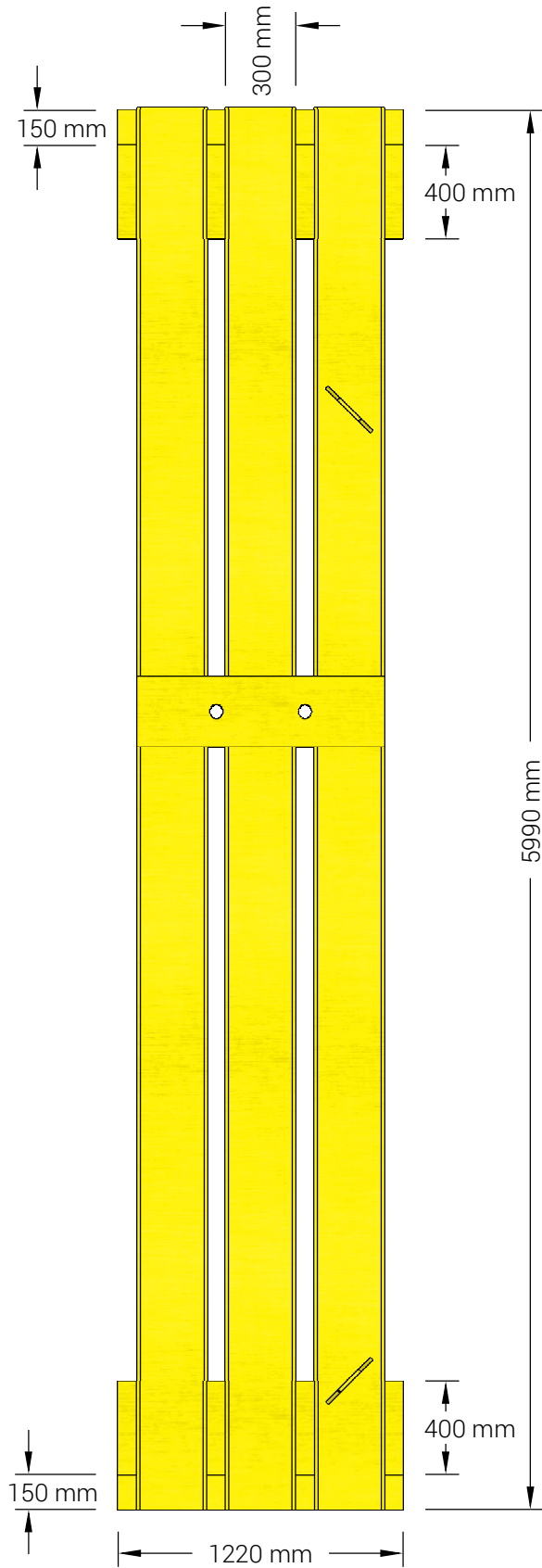
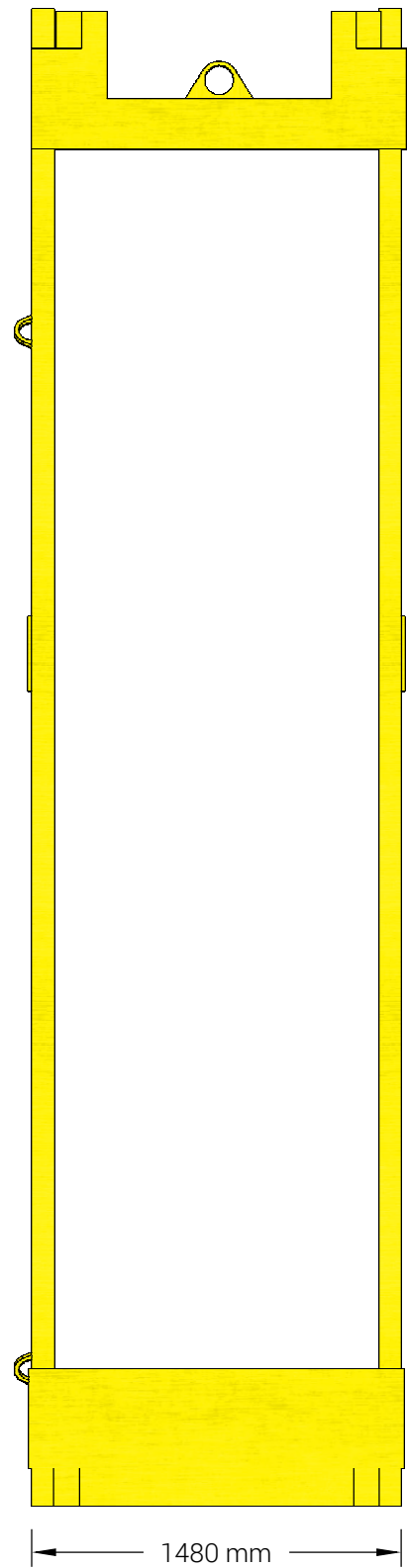
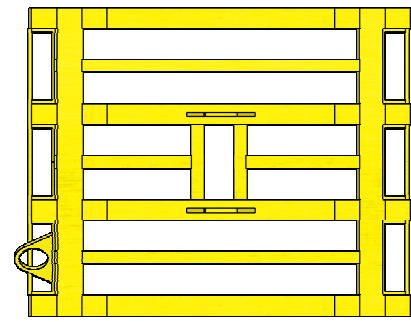

NOTES

Mass = 6000 kg

Each element has been proof tested up to 9 MN.

Typically referred to as 'hanger'

The tension element hangs from the secondary beams and provides a restraint lower than the load application providing increased stability and reducing the need for working at height. It is composed of high strength steel and at each end comprises a loading plate with integrated loading beams. Each end is connected by 6 no. 300 mm channels. A mid-span brace is attached on both sides and lifting eyes are integrated on two faces to allow both horizontal transport and vertical operation.

LOAD SADDLE SPECIFICATIONS

AUTHOR
M. Plummer

DATE
08/12/2020



DESCRIPTION
28 MN Reaction System Component Overview and Specification

REFERENCE
SCO/28.01

SCALE
1 : 20

PAGE
12

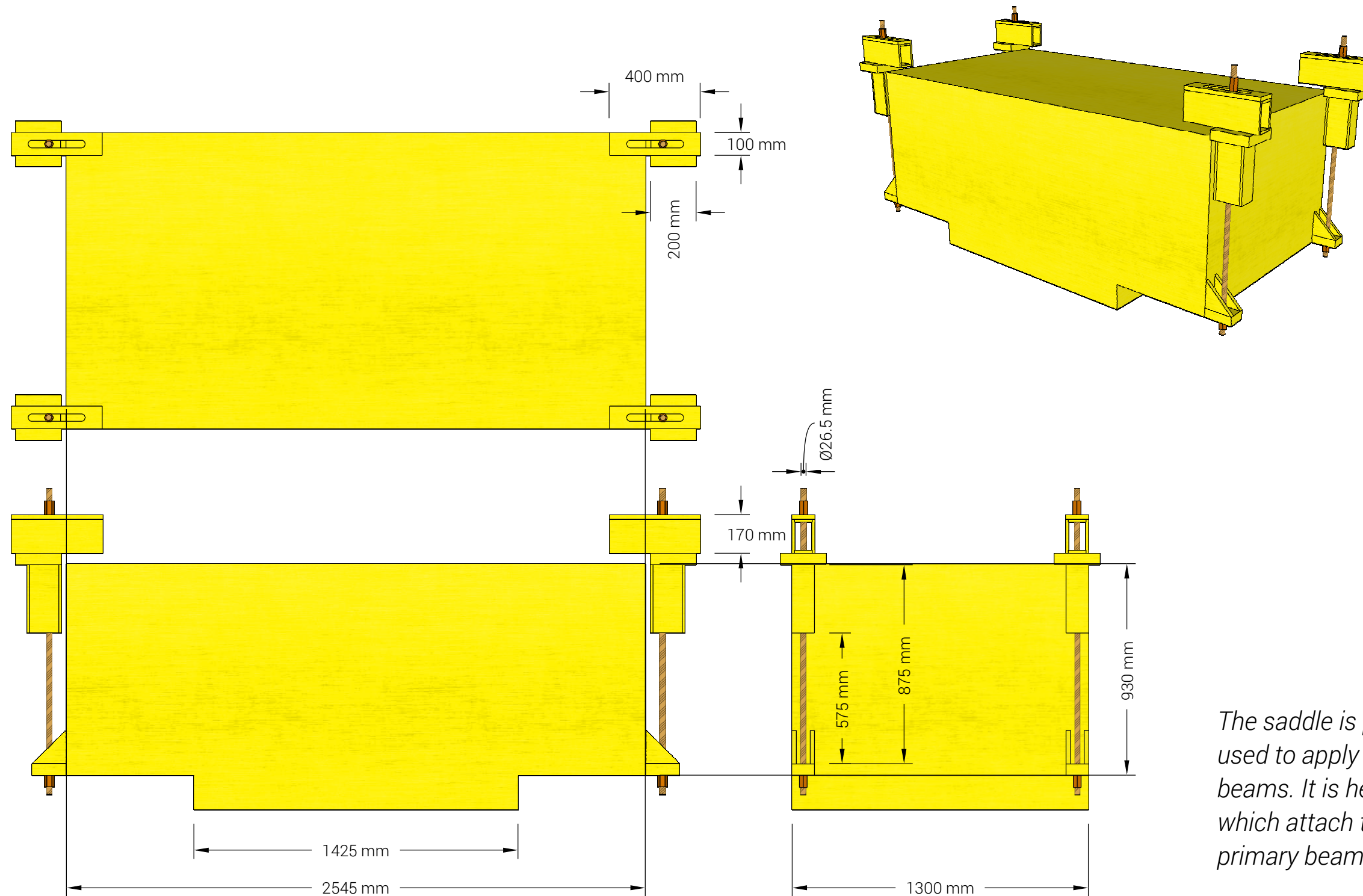

NOTES

Mass = 9000 kg

Capacity = 50 MN

The saddle is positioned above the test piles and is used to apply the load evenly in to the primary beams. It is held in place by four moveable clamps which attach to the bottom flange of the outermost primary beams.

TRESTLE SPECIFICATIONS

AUTHOR M. Plummer	DATE 08/12/2020	
DESCRIPTION 28 MN Reaction System Component Overview and Specification		
REFERENCE SCO/28.01	SCALE 1 : 30	PAGE 13

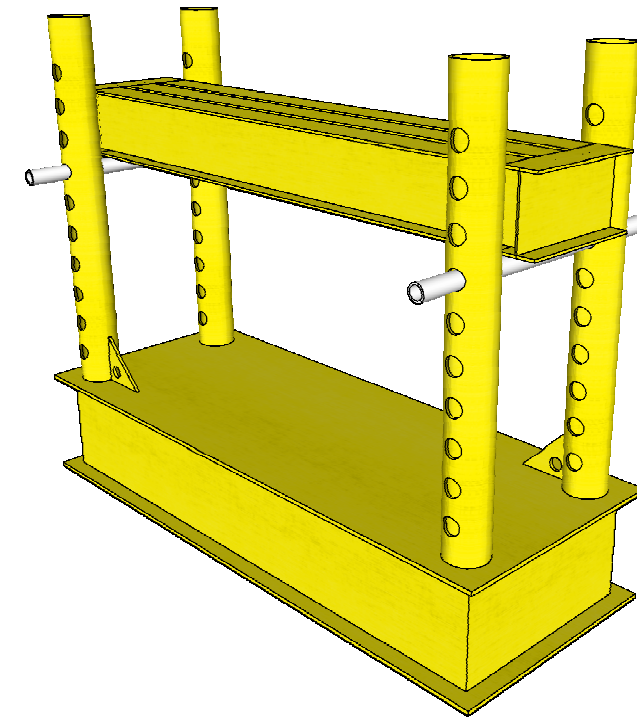
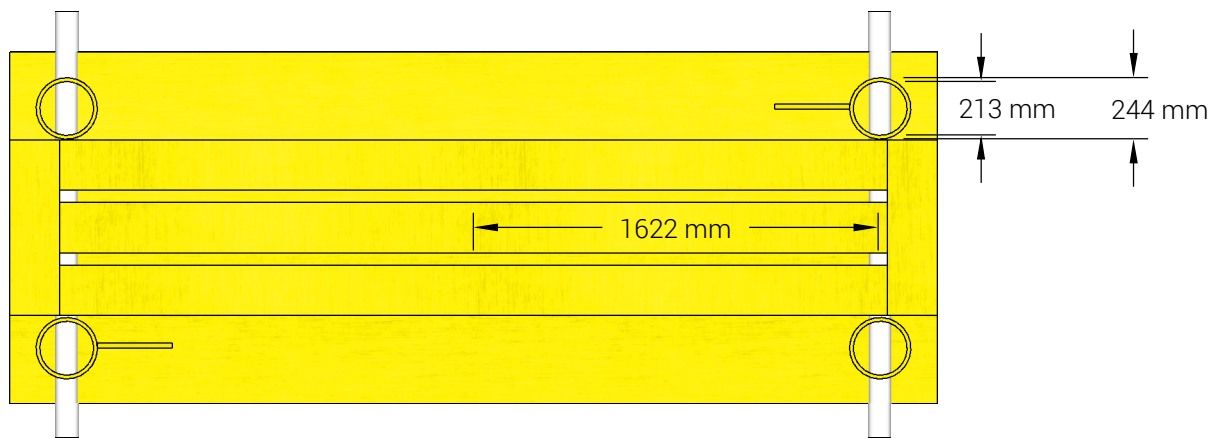

NOTES

Mass = 6000 kg

Each trestle is rated to carry 60000 kg.

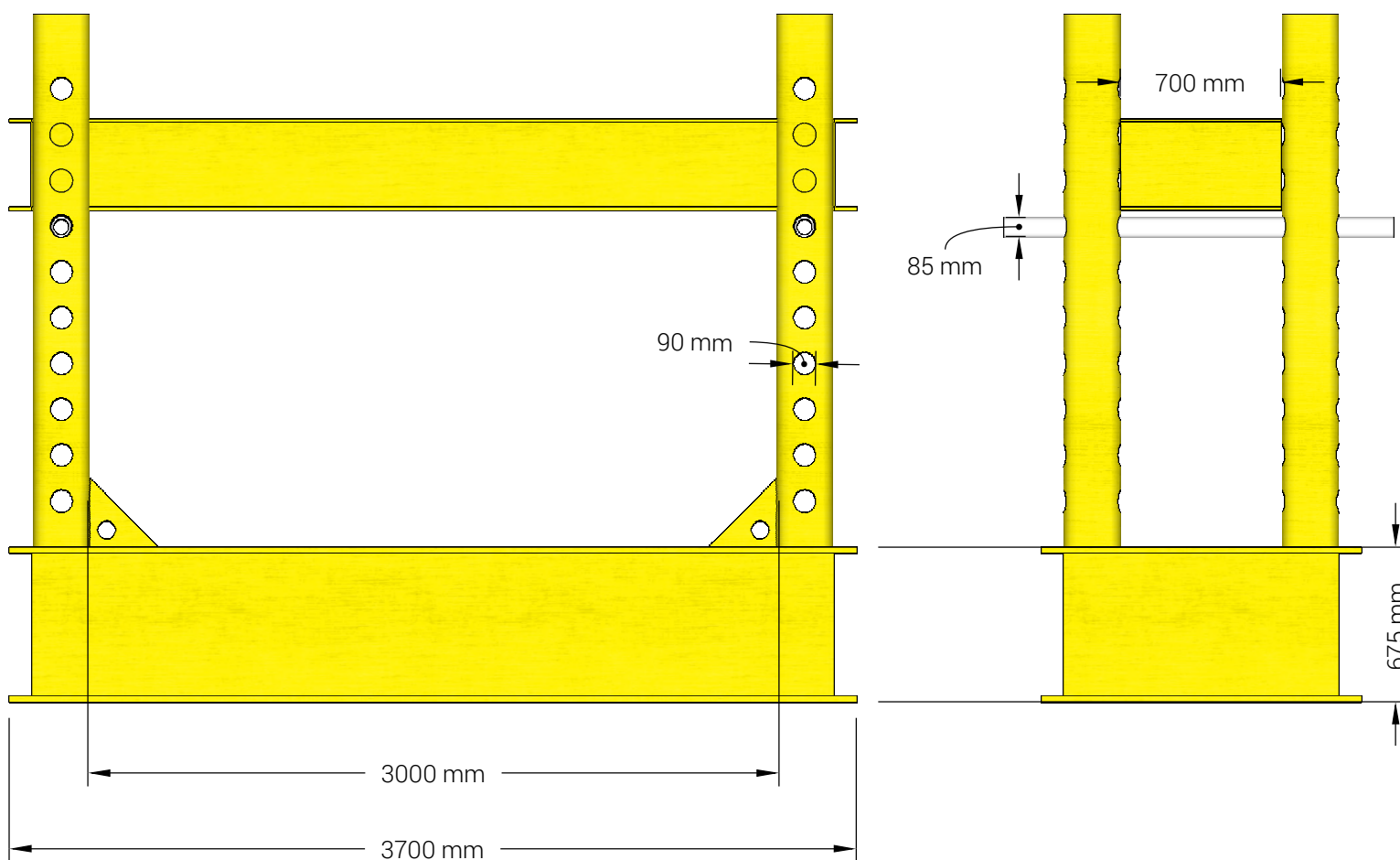

The trestles are used in pairs to support the beams and tension elements above the test pile. The main platform can be adjusted in height to suit the elevation of the test pile cap using removable, high strength pins. The trestle is composed of high strength steel and includes integrated lifting eyes.

HYDRAULIC ACTUATOR AND LOAD CELL DETAILS

AUTHOR M. Plummer	DATE 08/12/2020	
DESCRIPTION 28 MN Reaction System Component Overview and Specification		
REFERENCE SCO/28.01	SCALE 1:10	PAGE 14

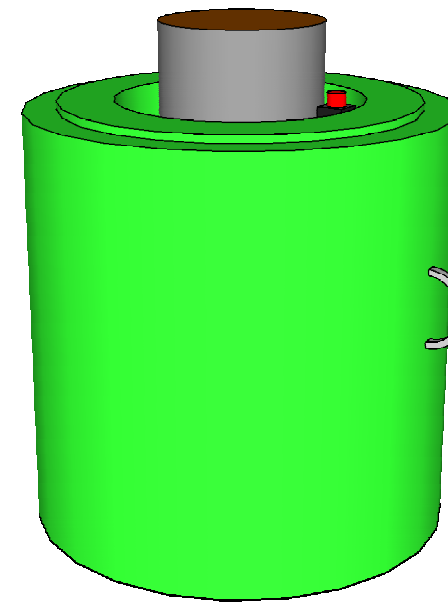
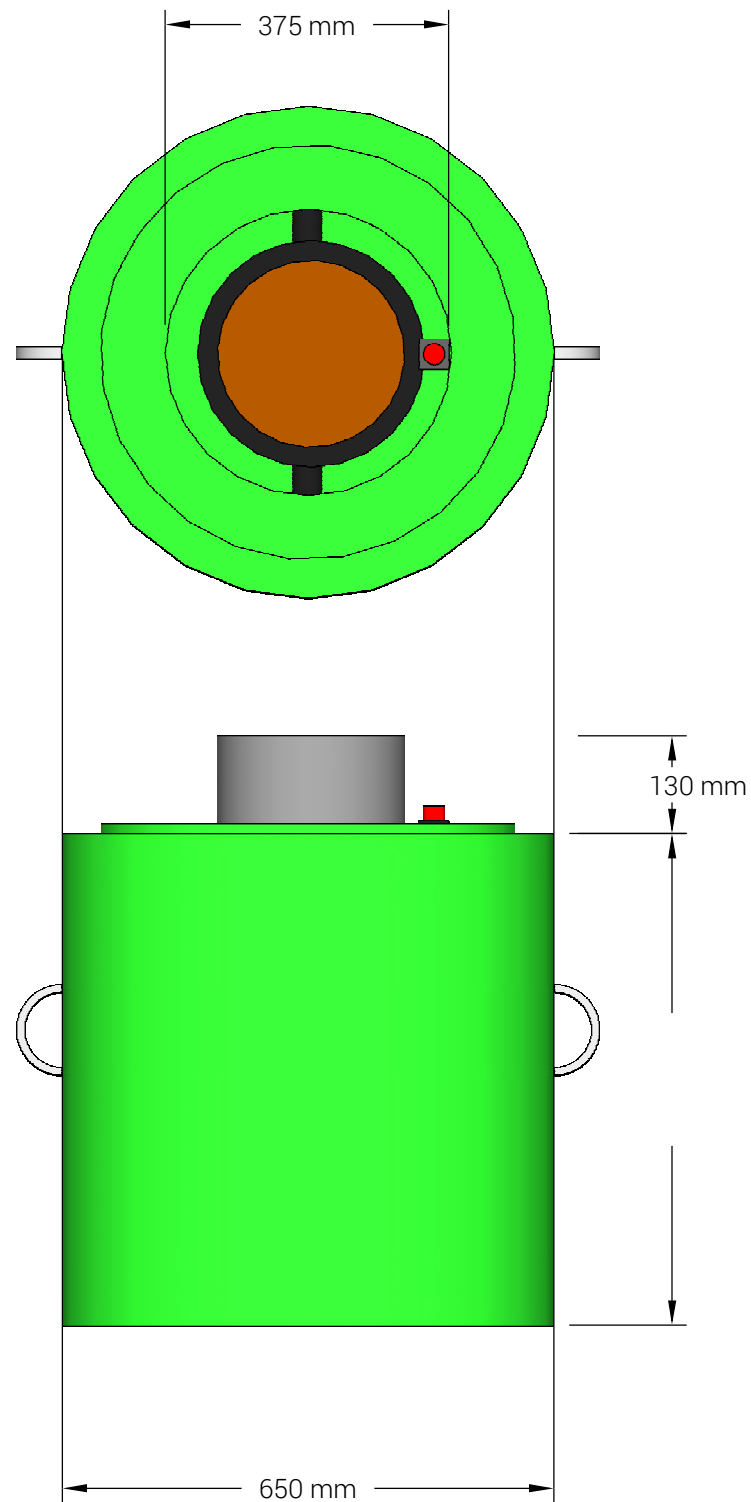

NOTES

- Combined mass = 1500 kg
- System working capacity = 15 MN
- Operating pressure = 690 bar
- Proof overload capacity = 23 MN

The hydraulic actuator is used to apply the load force to the foundation element. It has a maximum operating pressure of 690 bar with an over-pressure rating of 1035 bar. It has a maximum capacity of 15 MN and hydraulic stroke of 250 mm. It is fitted with two swivel lifting eyes for easy handling. For added safety and stability it has a recessed rod-end cavity to house the load cell.

The load cell is used to measure the force applied by the actuator. It is calibrated in-house to a maximum capacity of 15 MN with full UKAS standards traceability. It has two integrated lifting eyes and is transported in a separate casing before being located in to the recessed cavity on site during the build of the reaction system.