

S1000 Reaction System

Overview

The S1000 Reaction System comprises an S1000 primary beam and four S300 secondary beams and is used for load tests up to 10000 kN. A hydraulic actuator is used to apply the force to the test pile which is measured by a highly accurate load cell calibrated to UKAS standards with full traceability. Pile displacement is measured by four electronic displacement transducers mounted on an independent reference beam. The test is operated automatically by a bespoke system which can apply and remove load within a tolerance of ± 1 kN and monitors pile displacement to ensure settlement criteria meets the desired specification. Dynamic safety protocols run throughout the test to identify potential issues such as pile cap rotation and excessive reaction pile uplift. A remote link allows live monitoring of the load test throughout which is accessible through the SOCOTEC Foundations dedicated website. Tests can be carried out to any loading schedule or specification required and reaction piles can be monitored for load or displacement with the supplemental anchor monitoring kit.

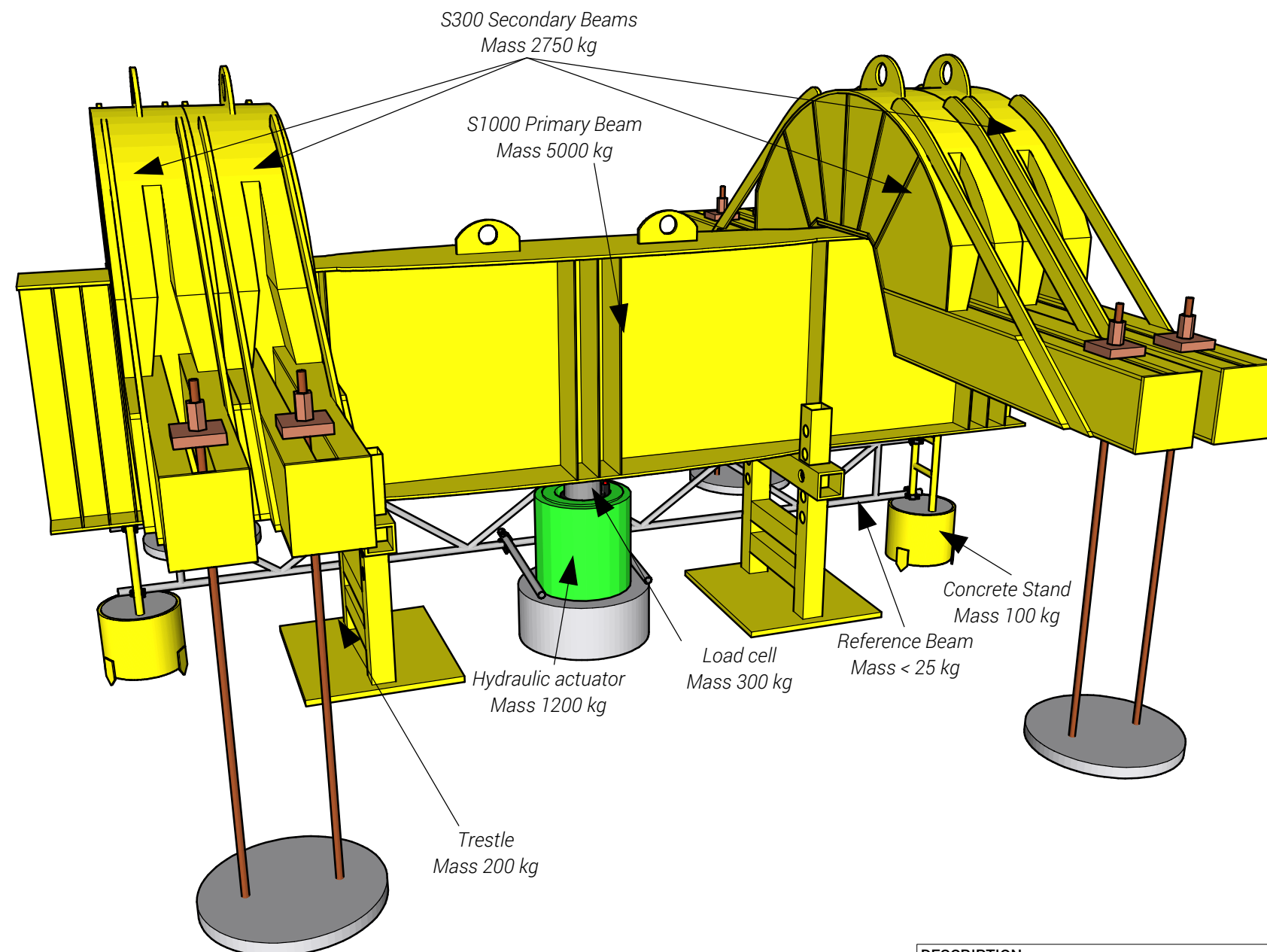

NOTES

- The hydraulic system has a maximum operating pressure of 690 bar with an over-pressure rating of 1035 bar
- The load cell includes a platen which can accommodate rotations of up to 10° mitigating any eccentric loading imposed by misalignment
- An exclusion zone of 10 m from the test pile is required to prevent site disturbance and unauthorised access
- The cranked design of the S300 secondary beams means that the point of load application is higher than the restraint points making it an inherently stable system

DESCRIPTION	REFERENCE	AUTHOR	DATE	SCALE	PAGE
S1000 Reaction System	S-MLT/GEN/S1000/3	M. Plummer	17/11/2022	NTS	1

S1000 Reaction System

Beam Dimensions

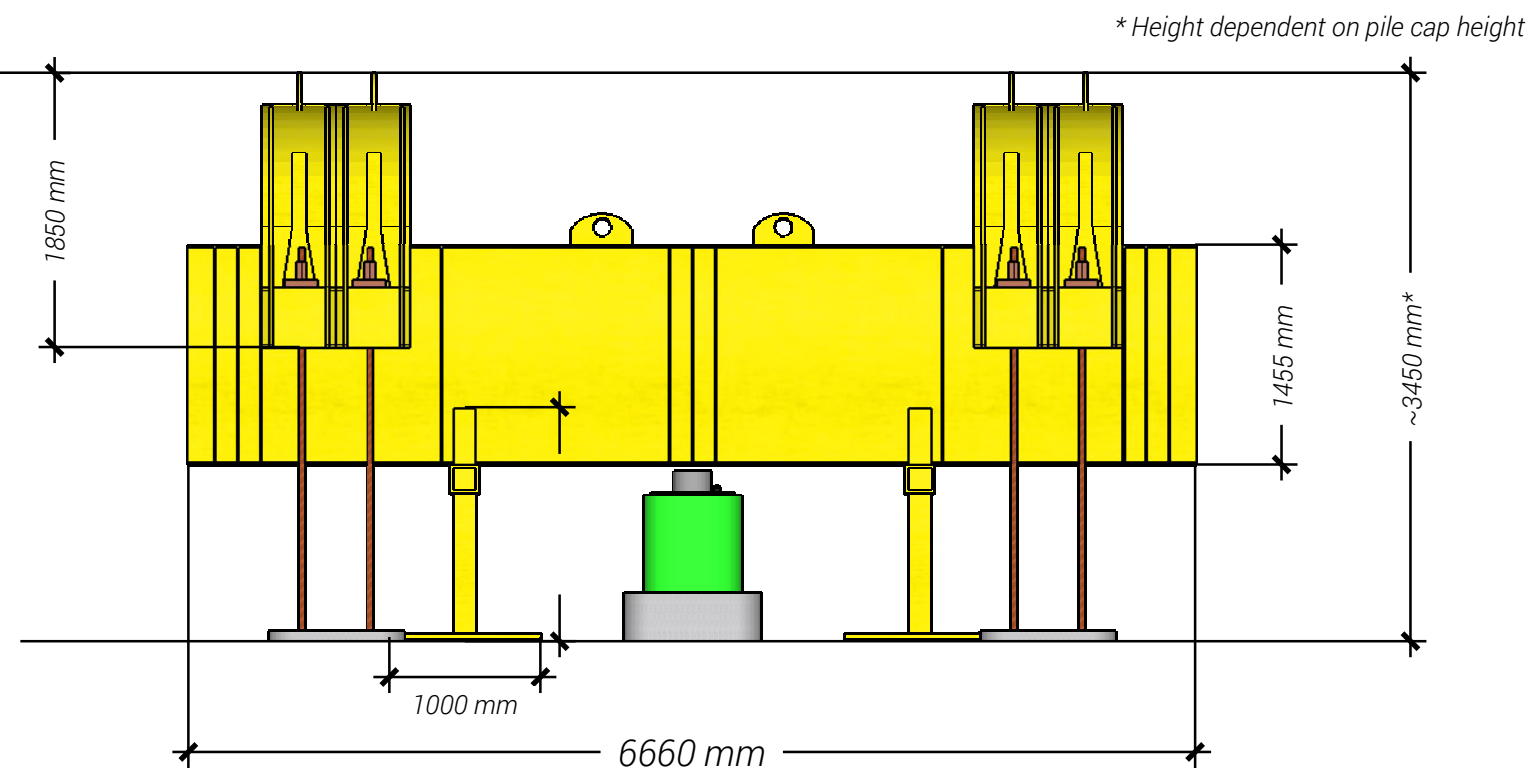
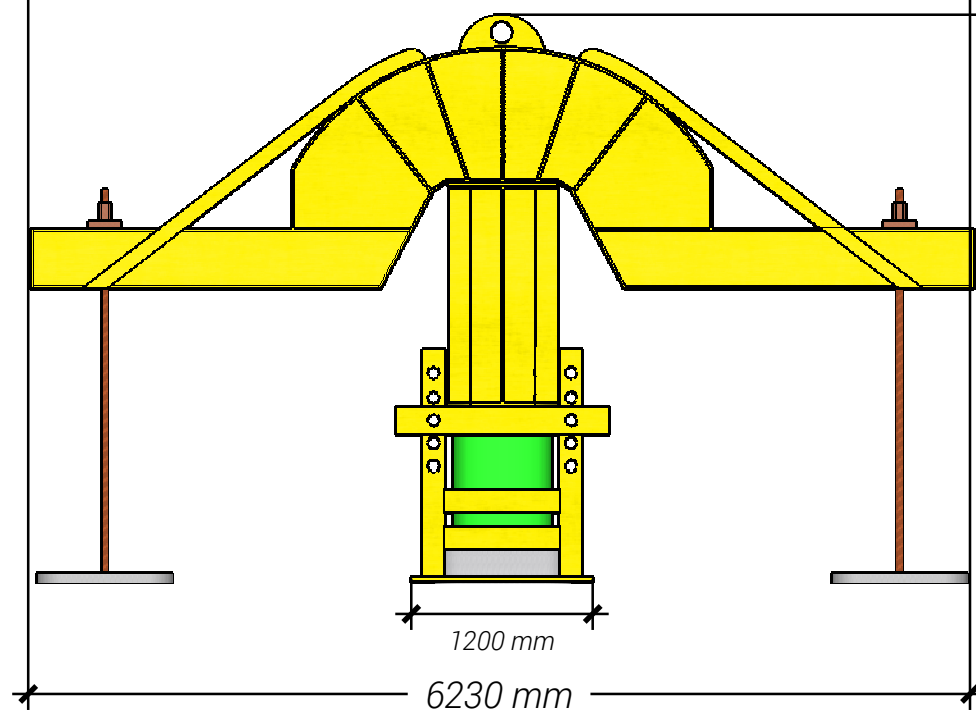
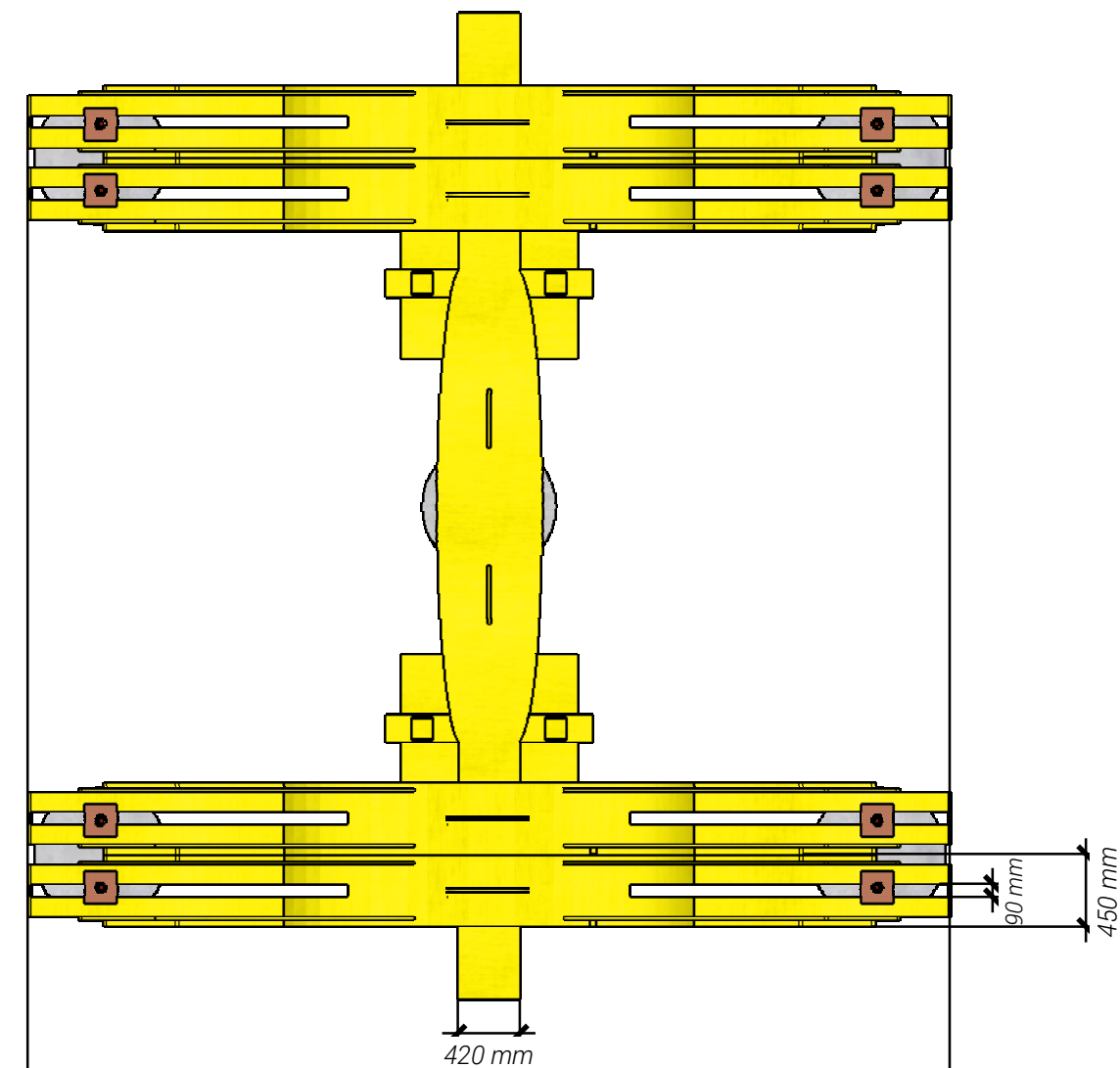

DESCRIPTION	REFERENCE	AUTHOR	DATE	SCALE	PAGE
S1000 Reaction System	S-MLT/GEN/S1000/3	M. Plummer	17/11/2022	NTS	2

S1000 Reaction System

Elevations

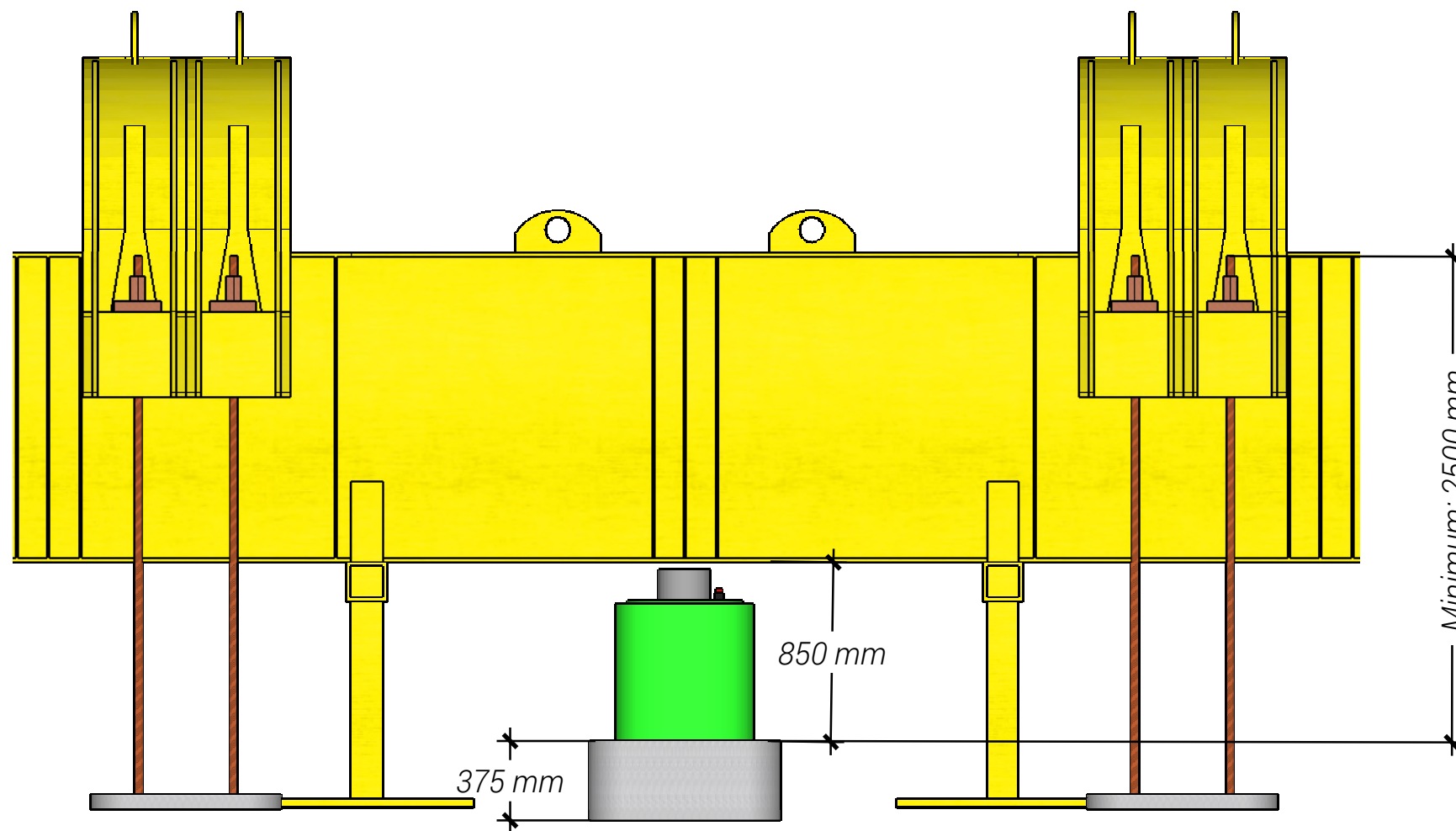

NOTES

- The test cap should be flat, smooth and level and designed to withstand the forces applied
- Threadbars should be installed within the extreme measurements shown, central about the anchor pile and in a line intersecting the test pile
- Tolerance on position of anchor piles and threadbars is ± 50 mm
- Threadbars should be vertical, cut squarely and free from concrete
- It is essential to avoid sources of heat like weld splatter on the threadbars to maintain structural integrity
- Threadbars should be selected so that the maximum load imposed does not exceed 75% of the bar's ultimate strength
- Mixing of bar quantity and diameters across anchor piles is not recommended. Capacity is always downrated to the weakest anchor configuration in this case
- SOCOTEC will only supply fixings and extensions for DSI Prestressing threadbar. GEWI and GEWI Plus are not supported

DESCRIPTION	REFERENCE	AUTHOR	DATE	SCALE	PAGE
S1000 Reaction System	S-MLT/GEN/S1000/3	M. Plummer	17/11/2022	NTS	3

S1000 Reaction System

Construction

Four anchors; two bars per anchor

Four anchors; four bars per anchor

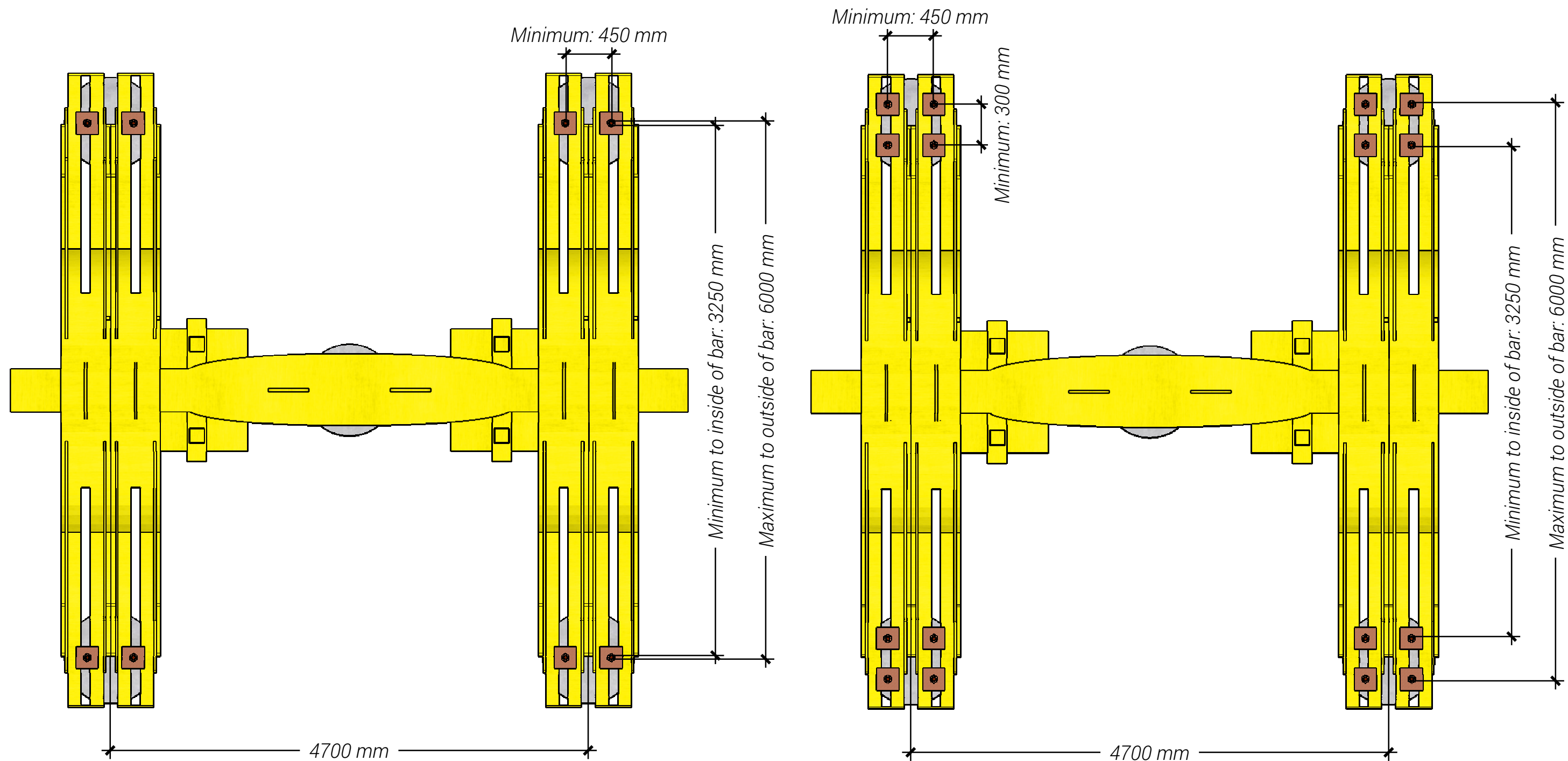

S1000 Reaction System

Construction

Eight anchors; two bars per anchor

Eight anchors; four bars per anchor

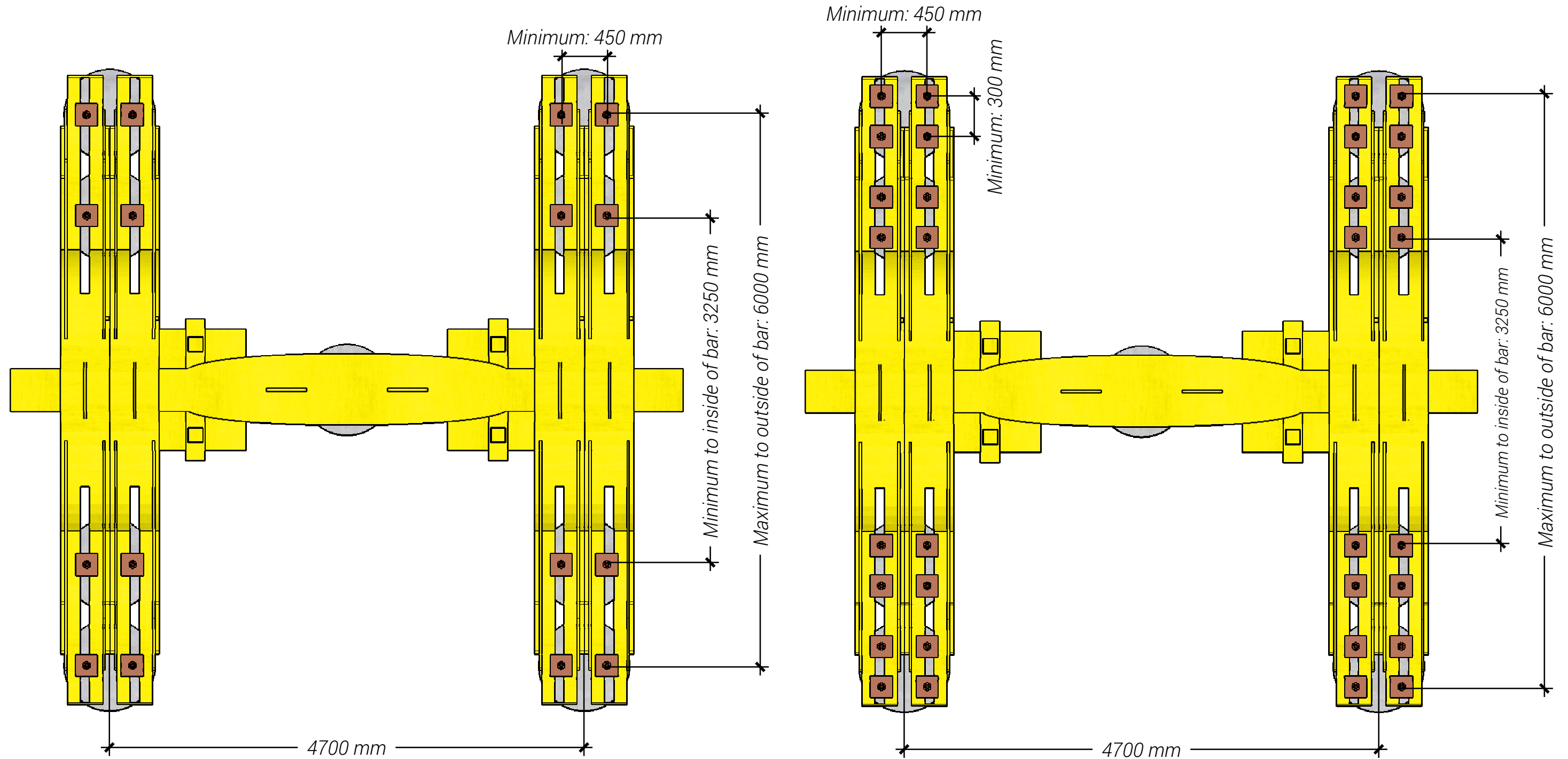

DESCRIPTION	REFERENCE	AUTHOR	DATE	SCALE	PAGE
S1000 Reaction System	S-MLT/GEN/S1000/3	M. Plummer	17/11/2022	NTS	5